

Features

- 1-channel signal conditioner
- 115 V AC supply
- Level sensing input
- Adjustable range 5 kΩ ... 150 kΩ
- Latching relay output
- Minimum/maximum control

Function

This signal conditioner provides the AC measuring voltage for the level-sensing electrodes.

Once the measured medium reaches the electrodes, the unit reacts by energizing a form C changeover relay contact.

The module is voltage and temperature stabilized and guarantees defined switching characteristics. An electronic holding circuit is used that allows minimum/maximum control. Since the conductance of the media may vary, the relay response sensitivity is adjustable.

The normal output state can be reversed through the mode of operation switch S1.

Assembly

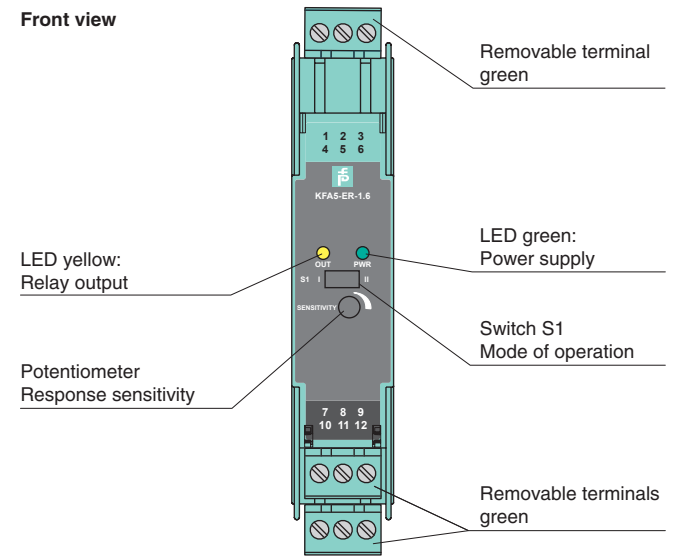

Connection

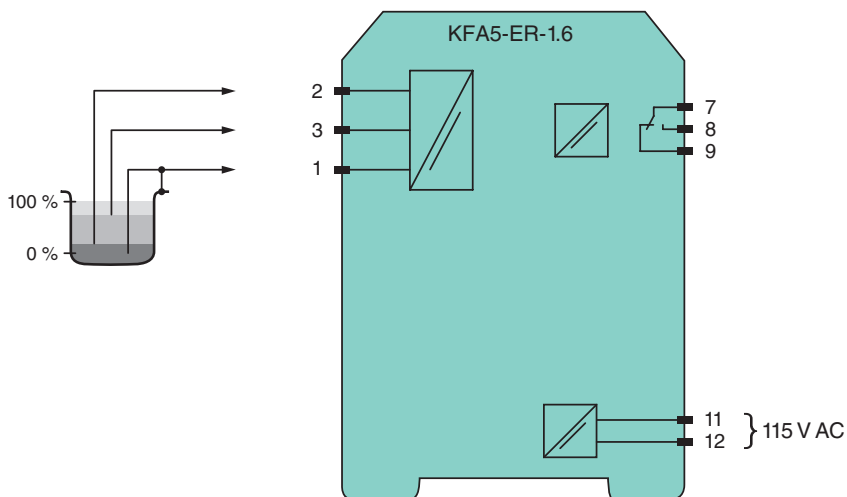

Release date 2009-05-06 17:43 Date of issue 2009-05-06 096048_ENG.xml

General specifications	
Signal type	Digital input
Supply	
Connection	terminals 11 (L1), 12 (N)
Rated voltage	103.5 ... 126 V AC , 45 ... 65 Hz
Power consumption	approx. 0.8 W
Input	
Connection	terminals 1 (mass), 2 (min), 3 (max)
Open circuit voltage/short-circuit current	approx. 10 V AC (approx. 1 Hz) / approx. 5 mA
Control input	min./max. control system: terminals 1, 2, 3 on/off control system: terminals 1, 3
Response sensitivity	5 ... 150 kΩ , adjustable via potentiometer (20 turns)
Output	
Connection	terminals 7, 8, 9
Output	1 changeover contact
Contact loading	253 V AC/2 A/cos φ > 0.7; 40 V DC/2 A resistive load
Energized/de-energized delay	approx. 1 s / approx. 1 s
Electrical isolation	
Input/output	basic insulation according to EN 50178, rated insulation voltage 253 V _{eff}
Input/power supply	basic insulation according to EN 50178, rated insulation voltage 253 V _{eff}
Output/power supply	basic insulation according to EN 50178, rated insulation voltage 253 V _{eff}
Directive conformity	
Electromagnetic compatibility	
Directive 2004/108/EC	EN 61326-1:2006
Low voltage	
Directive 2006/95/EC	EN 50178:1997
Conformity	
Insulation coordination	EN 50178
Electrical isolation	EN 50178
Electromagnetic compatibility	NE 21
Protection degree	IEC 60529
Ambient conditions	
Ambient temperature	-20 ... 60 °C (253 ... 333 K)
Mechanical specifications	
Protection degree	IP20
Connection	screw connection, max. 2.5 mm ²
Mass	approx. 110 g
Dimensions	20 x 107 x 115 mm (0.8 x 4.2 x 4.5 in) , housing type B1
Mounting	pull-out latches using for screw mounting
Indication and operation	
Operating elements	switch S1 Position I open circuit current: In the open circuit current principle, the relay becomes active when the limit is reached. Position II closed circuit current: In closed circuit current principle, the relay is activated when power is applied. The relay is deactivated when the limit is reached.
General information	
Supplementary information	Statement of Conformity, Declaration of Conformity and instructions have to be observed where applicable. For information see www.pepperl-fuchs.com .

Release date 2009-05-06 17:43 Date of issue 2009-05-06 096048_ENG.xml