

Features

- 2-channel isolated barrier
- 230 V AC supply
- Dry contact or NAMUR inputs
- Relay contact output
- Line fault detection (LFD)
- Reversible mode of operation
- Up to SIL2 acc. to IEC 61508

Function

This isolated barrier is used for intrinsic safety applications. It transfers digital signals (NAMUR sensors/mechanical contacts) from a hazardous area to a safe area.

The proximity sensor or switch controls a form C changeover relay contact for the safe area load. The normal output state can be reversed using switches S1 and S2. Switch S3 is used to enable or disable line fault detection of the field circuit.

During an error condition, the relays revert to their de-energized state and the LEDs indicate the fault according to NAMUR NE44.

Assembly

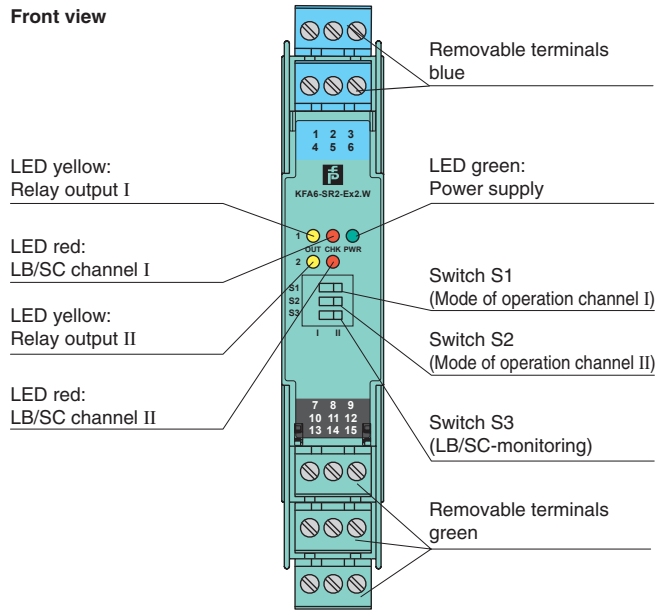

Connection

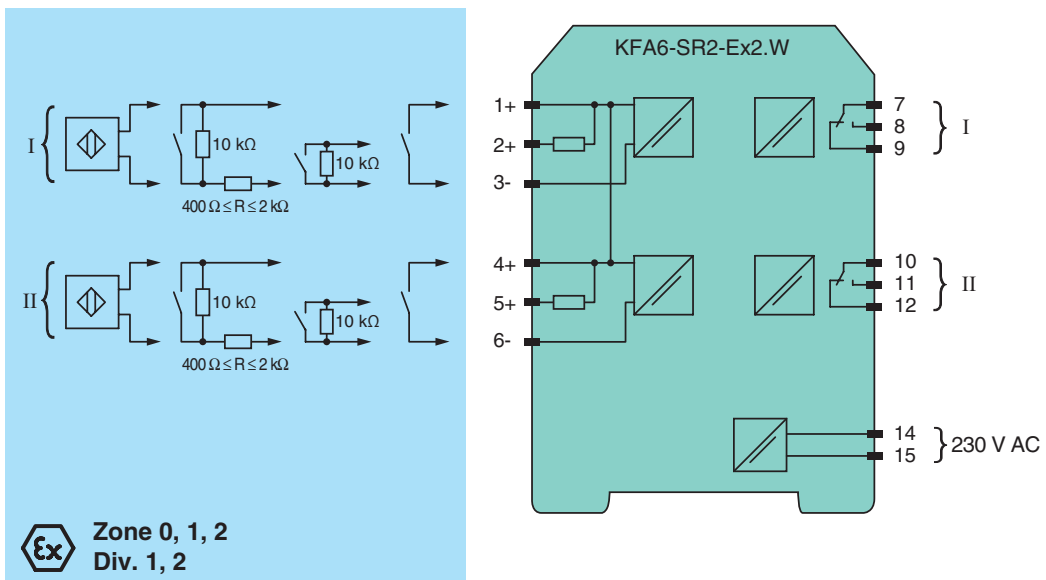

Release date 2009-05-28 17:48 Date of issue 2009-05-29 10:3373_ENG.xml

General specifications	
Signal type	Digital input
Supply	
Connection	terminals 14, 15
Rated voltage	207 ... 253 V AC, 45 ... 65 Hz
Power loss	1.2 W
Power consumption	≤ 1.3 W
Input	
Connection	terminals 1+, 2+, 3-; 4+, 5+, 6-
Rated values	acc. to EN 60947-5-6 (NAMUR)
Open circuit voltage/short-circuit current	approx. 8 V DC / approx. 8 mA
Switching point/switching hysteresis	1.2 ... 2.1 mA / approx. 0.2 mA
Line fault detection	breakage $I \leq 0.1$ mA , short-circuit $I > 6$ mA
Pulse/Pause ratio	≥ 20 ms / ≥ 20 ms
Output	
Connection	output I: terminals 7, 8, 9 ; output II: terminals 10, 11, 12
Output I, II	signal ; relay
Contact loading	253 V AC/2 A/cos $\phi > 0.7$; 126.5 V AC/4 A/cos $\phi > 0.7$; 40 V DC/2 A resistive load
Energized/de-energized delay	approx. 20 ms / approx. 20 ms
Mechanical life	10 ⁷ switching cycles
Transfer characteristics	
Switching frequency	≤ 10 Hz
Electrical isolation	
Output/power supply	reinforced insulation acc. to IEC 61140, rated insulation voltage 300 V _{rms}
Output/output	basic insulation according to IEC 61140, rated insulation voltage 300 V _{rms}
Directive conformity	
Electromagnetic compatibility	
Directive 2004/108/EC	EN 61326-1:2006
Low voltage	
Directive 2006/95/EC	EN 50178:1997
Conformity	
Electromagnetic compatibility	NE 21
Protection degree	IEC 60529
Protection against electric shock	IEC 61140
Ambient conditions	
Ambient temperature	-20 ... 60 °C (253 ... 333 K)
Mechanical specifications	
Protection degree	IP20
Mass	approx. 150 g
Dimensions	20 x 119 x 115 mm (0.8 x 4.7 x 4.5 in) , housing type B2
Data for application in conjunction with hazardous areas	
EC-Type Examination Certificate	PTB 00 ATEX 2081 , for additional certificates see www.pepperl-fuchs.com
Group, category, type of protection	⊕ II (1)GD [EEx ia] IIC [circuit(s) in zone 0/1/2]
Input	EEx ia IIC
Voltage U _o	10.6 V
Current I _o	19.1 mA
Power P _o	51 mW (linear characteristic)
Supply	
Safety maximum voltage U _m	253 V AC / 126.5 V AC (Attention! U _m is no rated voltage.)
Output	
Contact loading	253 V AC/2 A/cos $\phi > 0.7$; 126.5 V AC/4 A/cos $\phi > 0.7$; 40 V DC/2 A resistive load
Safety maximum voltage U _m	253 V AC (Attention! The rated voltage can be lower.)
Electrical isolation	
Input/input	not available
Input/output	safe electrical isolation acc. to EN 50020, voltage peak value 375 V
Input/power supply	safe electrical isolation acc. to EN 50020, voltage peak value 375 V
Directive conformity	
Directive 94/9/EC	EN 50014, EN 50020
International approvals	
FM approval	
Control drawing	116-0035
UL approval	
Control drawing	116-0145
CSA approval	

Release date 2009-05-28 17:48 Date of issue 2009-05-29 103373_ENG.xml

Control drawing	116-0047
General information	
Supplementary information	EC-Type Examination Certificate, Statement of Conformity, Declaration of Conformity and instructions have to be observed where applicable. For information see www.pepperl-fuchs.com .

Configuration

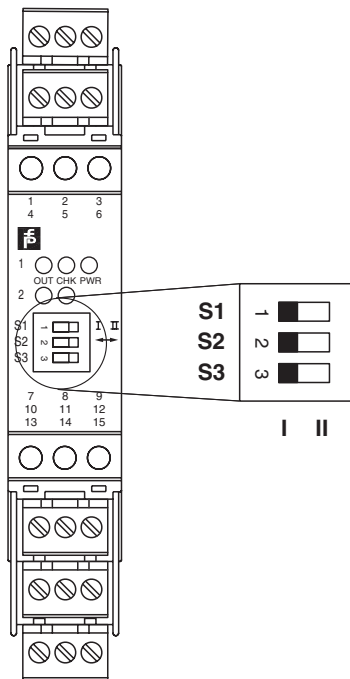

Switch position

S	Function		Position
1	Mode of operation Output I (relay) energized	with high input current	I
		with low input current	II
2	Mode of operation Output II (relay) energized	with high input current	I
		with low input current	II
3	Line fault detection	ON	I
		OFF	II

Operating status

Control circuit	Input signal
Initiator high impedance/ contact opened	low input current
Initiator low impedance/ contact closed	high input current
Lead breakage, lead short-circuit	Line fault

Factory settings: switch 1, 2 and 3 in position I