

**Features**

- 2-channel isolated barrier
- 115 V AC supply
- Dry contact or NAMUR inputs
- Latching relay output
- Line fault detection (LFD)
- Reversible mode of operation

**Function**

This isolated barrier is used for intrinsic safety applications. It has a latching relay (bistable operation) for level control, pump up/pump down, or other switch/logic applications. The device is set by an active signal on input I and is reset by an active signal on input II. The mode of operation of inputs I and II can be programmed.

Switch S3 is used to enable or disable line fault detection of the field circuit. During an error condition or loss of power, the form C changeover relays revert to their de-energized state and the LEDs indicate the fault according to NAMUR NE44. When the wiring fault is corrected, the relay will revert to the state prior to the fault.

If the device is re-energized after power loss, the relays return to a factory-configured state.

**Assembly**

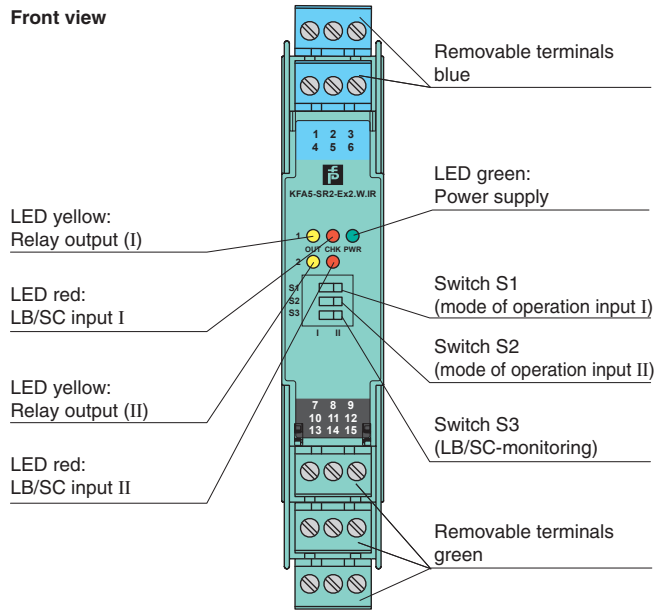

**Connection**

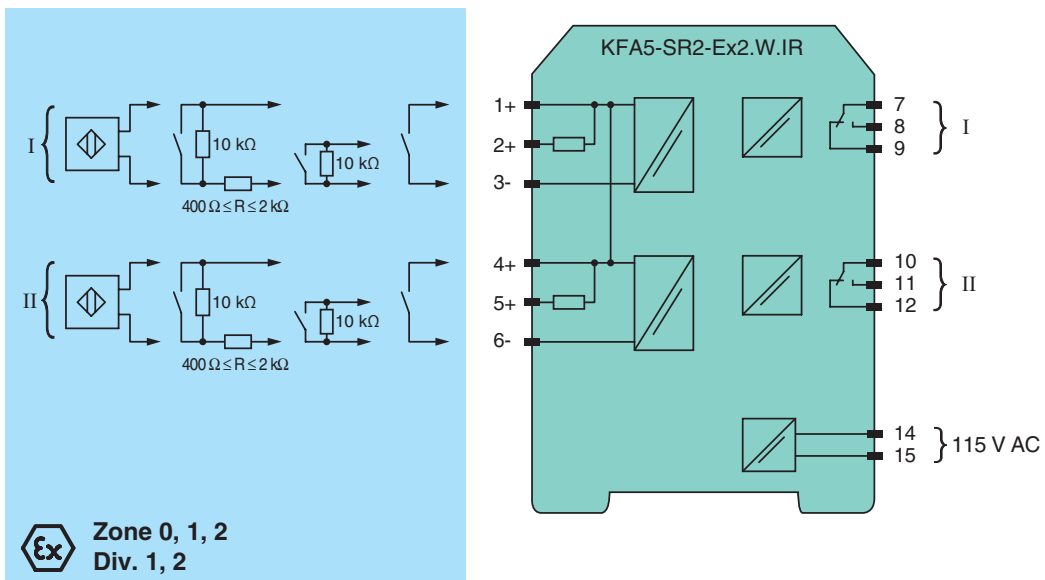

Release date 2009-05-28 17:48 Date of issue 2009-05-28 107809\_ENG.xml

<b>General specifications</b>	
Signal type	Digital input
<b>Supply</b>	
Connection	terminals 14, 15
Rated voltage	103.5 ... 126 V AC , 45 ... 65 Hz
Power consumption	≤ 1.5 W
<b>Input</b>	
Connection	terminals 1+, 2+, 3-; 4+, 5+, 6-
Rated values	acc. to EN 60947-5-6 (NAMUR)
Open circuit voltage/short-circuit current	approx. 8 V DC / approx. 8 mA
Line fault detection	breakage $I \leq 0.1$ mA , short-circuit $I > 6$ mA
Pulse/Pause ratio	≥ 10 ms / ≥ 10 ms
<b>Output</b>	
Connection	output I: terminals 7, 8, 9 ; output II: terminals 10, 11, 12
Output I, II	signal ; relay
Contact loading	253 V AC/2 A/cos $\phi > 0.7$ ; 126.5 V AC/4 A/cos $\phi > 0.7$ ; 40 V DC/2 A resistive load
Energized/de-energized delay	approx. 20 ms / approx. 20 ms
Mechanical life	10 <sup>7</sup> switching cycles
<b>Transfer characteristics</b>	
Switching frequency	≤ 10 Hz
<b>Electrical isolation</b>	
Output/power supply	safe isolation acc. to DIN VDE 0106, rated insulation voltage 253 V <sub>eff</sub>
Output/output	basic insulation acc. to EN 50178, rated insulation voltage 253 V <sub>eff</sub>
<b>Directive conformity</b>	
Electromagnetic compatibility	
Directive 2004/108/EC	EN 61326-1:2006
Low voltage	
Directive 2006/95/EC	EN 50178:1997
<b>Conformity</b>	
Electrical isolation	EN 50178
Electromagnetic compatibility	NE 21
Protection degree	IEC 60529
<b>Ambient conditions</b>	
Ambient temperature	-20 ... 60 °C (253 ... 333 K)
<b>Mechanical specifications</b>	
Protection degree	IP20
Mass	approx. 150 g
Dimensions	20 x 119 x 115 mm (0.8 x 4.7 x 4.5 in) , housing type B2
<b>Data for application in conjunction with hazardous areas</b>	
EC-Type Examination Certificate	PTB 00 ATEX 2081 , for additional certificates see <a href="http://www.pepperl-fuchs.com">www.pepperl-fuchs.com</a>
Group, category, type of protection	Ⓔ II (1)GD [EEx ia] IIC [circuit(s) in zone 0/1/2]
Input	EEx ia IIC
Voltage U <sub>o</sub>	10.6 V
Current I <sub>o</sub>	19.1 mA
Power P <sub>o</sub>	51 mW (linear characteristic)
Supply	
Safety maximum voltage U <sub>m</sub>	253 V AC / 126.5 V AC (Attention! U <sub>m</sub> is no rated voltage.)
Output	
Contact loading	253 V AC/2 A/cos $\phi > 0.7$ ; 126.5 V AC/4 A/cos $\phi > 0.7$ ; 40 V DC/2 A resistive load
Safety maximum voltage U <sub>m</sub>	253 V AC (Attention! The rated voltage can be lower.)
Electrical isolation	
Input/input	not available
Input/output	safe electrical isolation acc. to EN 50020, voltage peak value 375 V
Input/power supply	safe electrical isolation acc. to EN 50020, voltage peak value 375 V
Directive conformity	
Directive 94/9/EC	EN 50014, EN 50020
<b>International approvals</b>	
FM approval	
Control drawing	116-0035
UL approval	
Control drawing	116-0145
CSA approval	
Control drawing	116-0047
<b>General information</b>	

Release date 2009-05-28 17:48 Date of issue 2009-05-28 107809\_ENG.xml

## Supplementary information

EC-Type Examination Certificate, Statement of Conformity, Declaration of Conformity and instructions have to be observed where applicable. For information see [www.pepperl-fuchs.com](http://www.pepperl-fuchs.com).

**Configuration**

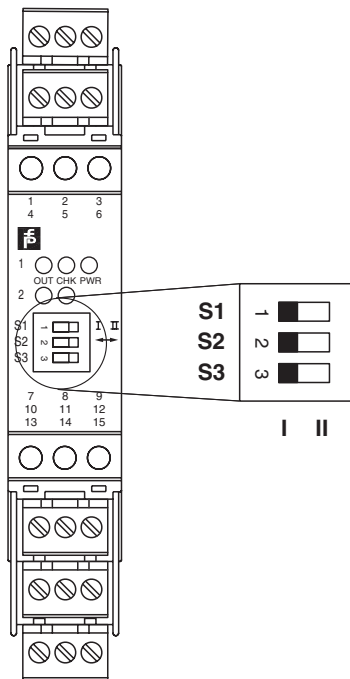

**Switch position**

S	Function		Position
1	Mode of operation Output I (relay) energized	with high input current	I
		with low input current	II
2	Mode of operation Output II (relay) energized	with high input current	I
		with low input current	II
3	Line fault detection	ON	I
		OFF	II

**Operating status**

Control circuit	Input signal
Initiator high impedance/ contact opened	low input current
Initiator low impedance/ contact closed	high input current
Lead breakage, lead short-circuit	Line fault

Factory settings: switch 1, 2 and 3 in position I