



- 1-channel
- Control circuit EEx ia IIC
- Reversible mode of operation
- 1 relay output with 1 changeover contact
- EMC acc. to NAMUR NE 21
- LB/SC monitoring
- Usable up to SIL2 acc. to IEC 61508

**100 V AC**  
**KFA4-SR2-Ex1.W**

**Function**

The transformer isolated barrier transfers digital signals from the hazardous area. Sensors per EN 60947-5-6 (NAMUR) and mechanical contacts may be used as alarms. Control circuits are monitored for lead breakage (LB) and short circuit (SC). The external faults are indicated according to NAMUR NE44 by a red flashing LED.

For type KFD2-SR2-Ex1.W, an LB/SC collective error message is in addition transferred through the Power Rail to the power feed module.

The intrinsically safe input is per EN 50020 safely isolated from the output and the power supply. The relay output is in accordance with IEC 61140 safely isolated from the power supply.

**Connection**

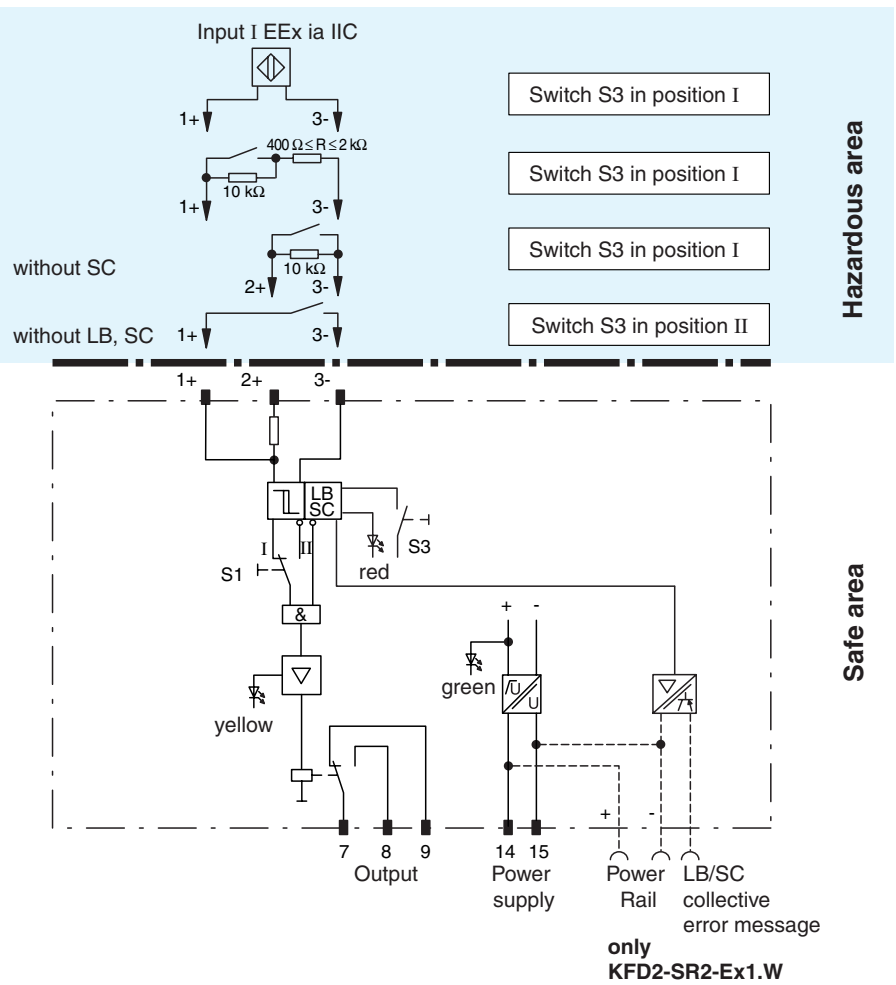

**Composition**

**Front View**

Housing type B2  
(see system description)

LED yellow:  
Relay output

LED red:  
LB/SC

Switch S2  
(no functions)

Removable terminal  
blue

LED green:  
Power supply

Switch S1  
(Mode of operation)

Switch S3  
(LB/SC-monitoring)

Removable terminals  
green

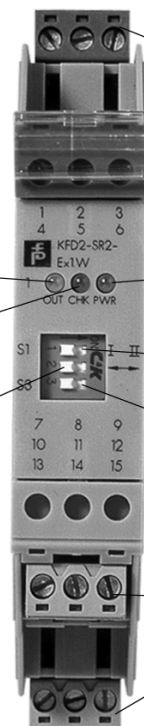

<b>General specifications</b>	
Signal type	Digital input
<b>Supply</b>	
Connection	terminals 14, 15
Rated voltage	90 ... 110 V AC , 45 ... 65 Hz
Ripple	-
Rated current	-
Power consumption	1 W
<b>Input</b>	
Connection	terminals 1+, 2+, 3-
Rated values	acc. to EN 60947-5-6 (NAMUR)
Open circuit voltage/short-circuit current	approx. 8 V DC / approx. 8 mA
Switching point/switching hysteresis	1.2 ... 2.1 mA / approx. 0.2 mA
Line fault detection	breakage $I \leq 0.1$ mA , short-circuit $I > 6$ mA
Pulse/Pause ratio	$\geq 20$ ms / $\geq 20$ ms
<b>Output</b>	
Connection	terminals 7, 8, 9
Output	signal ; relay
Contact loading	253 V AC/2 A/cos $\phi > 0.7$ ; 126.5 V AC/4 A/cos $\phi > 0.7$ ; 40 V DC/2 A resistive load
Energized/de-energized delay	approx. 20 ms / approx. 20 ms
Mechanical life	$10^7$ switching cycles
<b>Transfer characteristics</b>	
Switching frequency	< 10 Hz
<b>Electrical isolation</b>	
Output/power supply	reinforced insulation acc. to IEC 61140, rated insulation voltage 300 V <sub>rms</sub>
<b>Directive conformity</b>	
Electromagnetic compatibility	
Directive 2004/108/EC	EN 61326-1:2006
Low voltage	
Directive 2006/95/EC	EN 50178:1997
<b>Conformity</b>	
Electromagnetic compatibility	NE 21
Protection degree	IEC 60529
<b>Ambient conditions</b>	
Ambient temperature	-20 ... 60 °C (253 ... 333 K)
<b>Mechanical specifications</b>	
Protection degree	IP20
Mass	approx. 150 g
<b>Data for application in conjunction with hazardous areas</b>	
EC-Type Examination Certificate	PTB 00 ATEX 2081 , for additional certificates see <a href="http://www.pepperl-fuchs.com">www.pepperl-fuchs.com</a>
Group, category, type of protection	⊕ II (1)GD [EEx ia] IIC [circuit(s) in zone 0/1/2]
Input	EEx ia IIC
Voltage U <sub>o</sub>	10.6 V
Current I <sub>o</sub>	19.1 mA
Power P <sub>o</sub>	51 mW (linear characteristic)
<b>Supply</b>	
Safety maximum voltage U <sub>m</sub>	253 V AC / 126.5 V AC (Attention! U <sub>m</sub> is no rated voltage.)
<b>Output</b>	
Contact loading	253 V AC/2 A/cos $\phi > 0.7$ ; 126.5 V AC/4 A/cos $\phi > 0.7$ ; 40 V DC/2 A resistive load
Safety maximum voltage U <sub>m</sub>	253 V AC (Attention! The rated voltage can be lower.)
<b>Electrical isolation</b>	
Input/output	safe electrical isolation acc. to EN 50020, voltage peak value 375 V
Input/power supply	safe electrical isolation acc. to EN 50020, voltage peak value 375 V
<b>Directive conformity</b>	
Directive 94/9/EC	EN 50014, EN 50020

**Supplementary information**

EC-Type Examination Certificate, Statement of Conformity, Declaration of Conformity and instructions have to be observed. For information see [www.pepperl-fuchs.com](http://www.pepperl-fuchs.com).