

Features

- 1-channel signal conditioner
- 230 V AC supply
- Level sensing input
- Adjustable range 1 kΩ ... 150 kΩ
- Latching relay output
- Adjustable time delay up to 10 s
- Minimum/maximum control
- Line fault detection (LFD)

Function

This signal conditioner provides the AC measuring voltage for the level sensing electrodes.

Once the measured medium reaches the electrodes, the unit reacts by energizing a form C changeover relay contact.

The module is voltage and temperature stabilized and guarantees a defined switching characteristic.

It can be used for on/off control or minimum/maximum control. A signal delay feature is available and is adjustable between 0.5 s and 10 s.

This module can also monitor the field circuit for lead breakage (LB). LB is indicated by a red LED. If LB monitoring is selected, output II serves as the fault signal output; otherwise, it will follow the function of output I.

Assembly

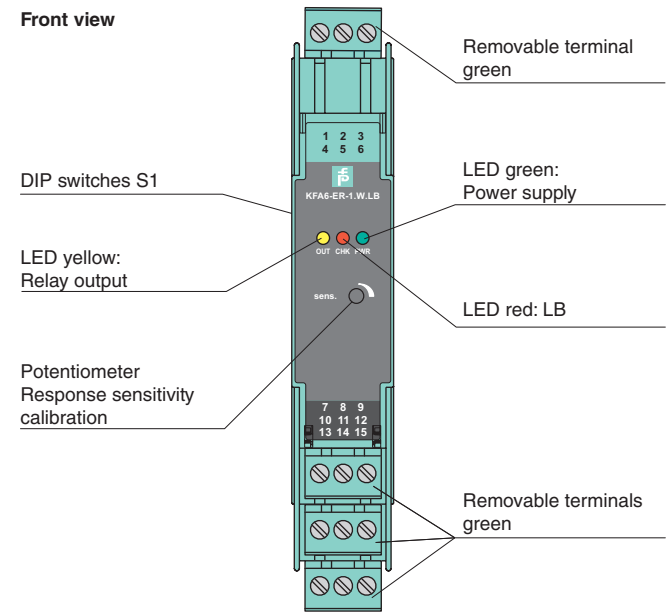

Connection

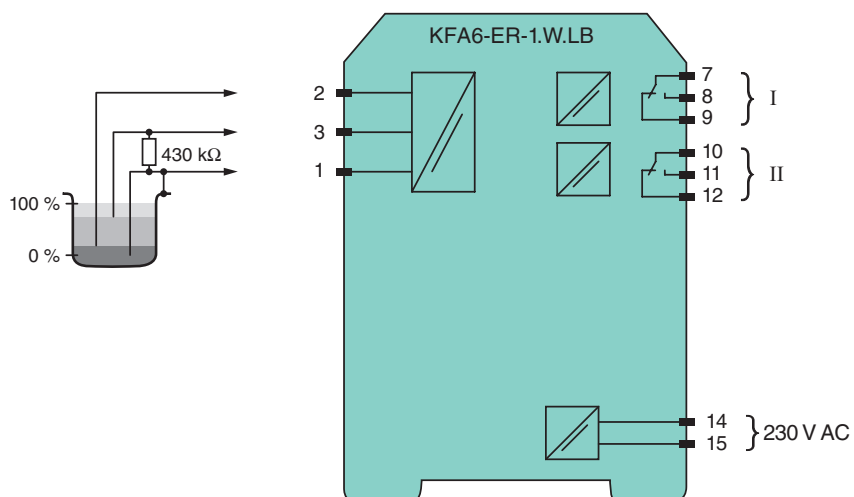

Release date 2009-05-06 17:43 Date of issue 2009-05-06 115619_ENG.xml

General specifications	
Signal type	Digital input
Supply	
Connection	terminals 14, 15
Rated voltage	207 ... 253 V AC, 45 ... 65 Hz
Rated current	≤ 7 mA
Power consumption	< 1.2 W
Input	
Connection	terminals 1 (mass), 2 (min), 3 (max)
Control input	min./max. control system: terminals 1, 2, 3 on/off control system: terminals 1, 3
Response sensitivity	1 ... 150 kΩ , adjustable via potentiometer
Output	
Connection	terminals 7, 8, 9; 10, 11, 12
Switch power	max. 192 W , 2000 VA
Output	relay
Contact loading	253 V AC/2 A/cos φ > 0.7; 40 V DC/2 A resistive load
Time constant for signal damping	0.5 s, 2 s, 5 s, 10 s
Electrical isolation	
Input/output	basic insulation according to EN 50178, rated insulation voltage 253 V _{eff}
Input/power supply	basic insulation according to EN 50178, rated insulation voltage 253 V _{eff}
Output/power supply	basic insulation according to EN 50178, rated insulation voltage 253 V _{eff}
Directive conformity	
Electromagnetic compatibility	
Directive 2004/108/EC	EN 61326-1:2006
Low voltage	
Directive 2006/95/EC	EN 50178:1997
Conformity	
Insulation coordination	EN 50178
Electrical isolation	EN 50178
Electromagnetic compatibility	NE 21
Protection degree	IEC 60529
Ambient conditions	
Ambient temperature	-20 ... 60 °C (253 ... 333 K)
Mechanical specifications	
Protection degree	IP20
Connection	screw connection, max. 2.5 mm ²
Mass	approx. 150 g
Dimensions	20 x 119 x 115 mm (0.8 x 4.7 x 4.5 in) , housing type B2
Mounting	pull-out latches using for screw mounting
General information	
Supplementary information	Statement of Conformity, Declaration of Conformity and instructions have to be observed where applicable. For information see www.pepperl-fuchs.com .

Configuration

DIP switch function on side of device

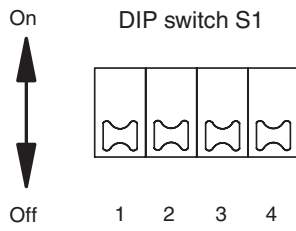

Switches	Position	Function
1	Off	open circuit current
	On	closed circuit current
2	Off	LB deactivated
	On	LB activated

Switch 3	Switch 4	Time constant for signal damping
Off	Off	0.5 s
Off	On	2 s
On	Off	5 s
On	On	10 s

- Open circuit current principle: In open circuit current principle the relay becomes active when the limit is reached.
- Closed circuit current principle: In closed circuit current principle, the relay is activated when power is applied. The relay is deactivated when the limit is reached.